



2 Block Dry Block Heaters



Ph 0800 27 26 26

info@ansutek.co.nz
www.ansutek.co.nz
www.ansutekbiz.co.nz



Versatile Block Heaters Designed for Everyday Use with Accessories for Every Application

Versatile Dry Block Heaters are ideal for applications that require temperature stability. Close tube-to-block contact enables maximum heat retention, resulting in efficient heating. Digital models offer exceptional temperature uniformity and stability for repeatable results, while non-digital models are an economical choice. All units hold optional interchangeable modular blocks with over 40 choices. Blocks are easy to use, no tools required.

Standard Features:

- **Delivering Exceptional Temperature Stability and Uniformity**
Three models to customize your application. All models offer exceptional temperature uniformity with outstanding temperature stability.
- **Heated Lid Model Reduces Condensation on Lids to Maintain Sample Integrity**
A second heater in the lid helps minimize condensation to maintain sample integrity, providing reliable, repeatable results. Easily monitor settings with independent displays for temperature and time.
- **Calibrate to an External Temperature Device with Temperature Calibration Mode**
Digital models with user calibration feature allows you to match the Block Heater's display to your known external temperature standard which improves the temperature accuracy of the system.

2 Block Dry Block Heaters

Model	HB2AL	HB2DG	HB2DGHL
Control	Non-Digital	Digital	Digital
Temperature Range	Low Ambient + 5 °C – 100 °C, High 75 °C – 150 °C	Ambient + 5 °C – 120 °C	Ambient + 5 °C – 100 °C
Stability @ 37 °C	+/-1.5°C (120V) +/-2°C (230V)	+/-0.1°C (120V) +/-0.2°C (230V)	+/-0.1°C (120V) +/-0.1°C (230V)
Uniformity within the block @ 37 °C	+/-0.1°C (120V) +/-0.4°C (230V)	+/-0.1°C (120V) +/-0.2°C (230V)	+/-0.1°C (120V) +/-0.1°C (230V)
Heat Up Time to 100 °C	≤ 16 min		≤ 30 min
Temperature Calibration	NA	•	
Number of Blocks	2		
Overshoot Protection	NA	10 °C above set point	
Working Environment	18 °C – 33 °C, 20% – 80% Relative humidity, non-condensing		
Power	230V, 0.92A, 50/60Hz		230V, 1.65A, 50/60Hz
Power Consumption	210 W		400 W
Dimensions (W × L × H)	203 × 391 × 89 mm		203 × 391 × 178 mm
Net Weight	2.8 kg		3.1 kg

Other Standard Features and Equipment

Touchpad control and audible alarm (digital models), painted steel housing, digital models include support rod holder with locking knob, detachable 3-wire cord and plug (included)

Compliance

- **Product Safety:** EN 61010-1, EN 61010-2-051
- **Electromagnetic Compatibility:** EN 61326-1 Class A, Industrial Environments
- **Compliance Marks:** CE; RCM; TÜV SÜD

Accessories

Module Block 10 mm Test Tube, 24 Wells	30400151	Module Block 15 mL Conical Centrifuge, 12 Wells***	30400172
Module Block 12/13 mm, 20 Wells	30400152	Sand Bath, 2 Block Unit.....	30400174
Module Block 15/16 mm, 12 Wells***	30400153	Sand, 0.5 kg Bag.....	30400177
Module Block 20 mm Test Tube, 8 Wells***	30400154	Stainless Steel Shot, 0.5 kg	30400178
Module Block 25 mm Test Tube, 6 Wells***	30400155	Cover Low-Temperature 2 Block*	30400179
Module Block Combo - Test Tube Combination Block:		Module Block For Vials 12 mm, 20 Wells	30400182
6 mm, 12/13 mm, 25 mm***	30400156	Module Block For Vials 15 mm, 20 Wells	30400183
Module Block 0.5 mL Microtaper, 30 Wells	30400157	Module Block For Vials 17 mm, 12 Wells	30400184
Module Block 6 mm Test Tube, 30 Wells	30400158	Module Block For Vials 19 mm, 12 Wells	30400185
Module Block 1.5 mL Microtaper, 20 Wells	30400159	Module Block For Vials 21 mm, 9 Wells	30400186
Module Block Solid	30400160	Module Block For Vials 23 mm, 8 Wells	30400187
Module Block Cuvette - 12 Cuvet, 2 Wells	30400161	Module Block For Vials 25 mm, 8 Wells	30400188
Module Block 11.5/1.5 mL Microcentrifuge, 20 Wells		Module Block For Vials 28 mm, 6 Wells	30400189
.....	30400162	Module Block For Vials 16 mm, 15 Wells	30400190
Module Block 250 Microliter/6 mm, 30 Wells	30400163	Module Block, 2.0 mL Tube, 20 Wells	30400191
Module Block Titer Plate	30400164	Module Block, 2.0 mL Corning Tube, 20 Wells	30400192
Module Block 12/13 mm, 16 Wells	30400165	Module Block Combo - Centrifuge Tube Configuration:	
Module Block Solid Double	30400166	50 mL-2 Wells, 15 mL-3 Wells, 1.5 mL-4 Wells***	30400193
Module Block 35 mm Test Tube, 4 Wells***	30400167	Module Block Combo - Micro Tube Combination:	
Module Block 50 mL Conical Centrifuge, 5 Wells***	30400168	2 mL-5 Wells, 1.5 mL-10 Wells, 0.5 mL-6 Wells	30400194
Module Block 0.2 mL Micro, 80 Wells	30400169	Module Block 17/18 mm, 12 Wells***	30400195
Module Block 0.2 mL Micro, 64 Wells	30400170	Stainless Steel Probe Kit**	30400246
Module Block 0.2 mL 96 Hole Double Block	30400171		

*NA for HB2DGHL **NA for HB2AL ***Dry Block Heater HB2DGHL accommodates various tube sizes up to 85mm in height

Dimensions

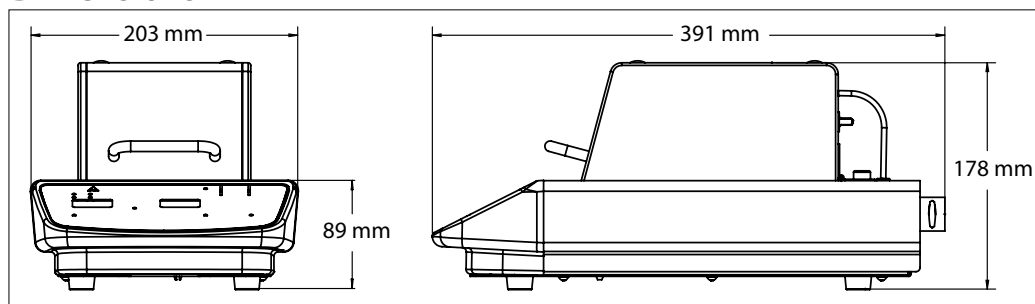

info@ansutek.co.nz
www.ansutek.co.nz
www.ansutekbiz.co.nz

The management system governing the manufacture of this product is ISO 9001:2015 certified.

30385218

